

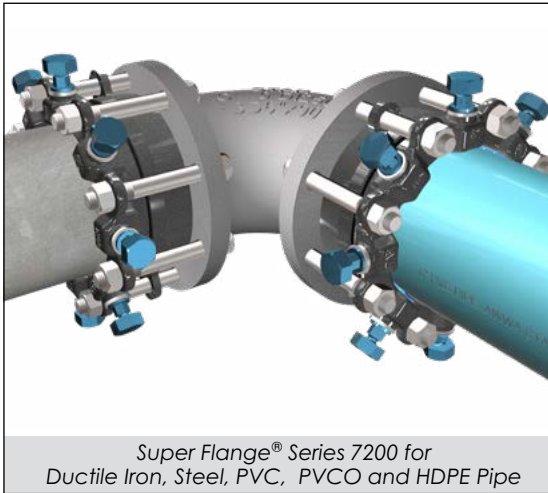

Super Flange® series 7200

Designed for use on Ductile Iron, Steel, PVC, PVCO and HDPE Pipes

Sizes 3" - 36"



Super Flange® Series 7200 for Ductile Iron, Steel, PVC, PVCO and HDPE Pipe

INFORMATION

The Series 7200 Super Flange® is a restrained flange adapter designed to connect plain end pipe to a flange end component. May be installed on ductile iron, steel, PVC, PVCO and HDPE pipe.

Restrains and Adapts Plain End Pipe to Flanged Components



FEATURES & ADVANTAGES

- Versatile product designed for adapting metal and plastic pipe to flange connections.
- Designed for use on ductile iron pipe for 3" to 36" with pressure ratings up to 350 psi.
- Rated to 350 psi on steel pipe for 3" to 12". A transition gasket is required.
- Approved on AWWA C900 PVC pipe, IPS PVC pipe, AWWA C909 PVCO pipe, and HDPE pipe. See pressure rating table for approved DRs and sizes. Plastic pressure pipes manufactured to an IPS diameter regimen will require a transition gasket.
- Joint deflection up to 5° maximum
- Allows for field flanged ends on plain end pipe
- Flange meets ANSI Class 125/150 and ANSI/AWWA C115/A21.15 drill pattern.
- MJ gasket and O-ring flange gasket are made from styrene butadiene rubber (SBR) per ANSI/AWWAC111/A-21.11.
- Includes restraint gland, flange adapter ring, gaskets and hex head bolts/nuts
- Restraint gland is coated with StarBond™ (polyester).
- Flange adapter ring coated with fusion bonded epoxy.
- Super Flange® sizes 3"-12" are listed with Underwriters Laboratories Inc. and Underwriters Laboratories of Canada for ductile iron and steel pipe at 350 psi.
- Super Flange® sizes 4" – 12" are approved by Factory Mutual Research for use on DR18 AWWA C900 PVC pipe and sizes 4"-10" on DR14.
- Wedges are heat treated to a minimum 370 BHN
- When installed on IPS pipe in sizes 4" to 12", the spacers must be removed.
- May also be used on steel pipe of any size. For steel pipe 12" and under a transition gasket is required if the diameter regimen is IPS. For steel pipe 14" and larger, the pipe's outside diameter must be the same as ductile iron pipe (CIOD diameter regimen). For sizes 3" – 8", minimum SCH40 steel pipe wall thickness is required. For sizes 10" through 16" the minimum wall thickness must be equal to or greater than PC350 ductile iron pipe. For sizes 18" and above, the minimum wall thickness of the steel pipe must be equal to or greater than PC 250 ductile iron pipe.

SAMPLE SPECIFICATIONS

Restrainer mechanism shall be integrated into the design of the restraint gland. As the mechanism is activated, multiple wedging action shall be imparted against the pipe increasing its resistance as internal pressure increases. After burial of the restraining mechanism, joint flexibility shall be maintained.

The actuating bolt shall be threaded into the gland and have a 1-1/4" hex operating nut. The actuating bolt system shall have a torque-limiting head designed to break off at preset torque levels, thus insuring proper action of the restraining device. After removal of the torque-limiting head, a 5/8" hex head shall remain to facilitate the removal and re-assembly of the gland. Glands, bolts and wedges shall be manufactured of high strength ductile iron in accordance with ASTM A536 Grade 65-45-12 requirements. Wedges shall be heat treated to a minimum hardness of 370 BHN.

All internal and external surfaces of flange adapter ring will have fusion bonded epoxy per requirements of ANSI/AWWA C116/A 21.16. Coatings and gaskets to meet ANSI/NSF-61. The restraint mechanism shall have a 2:1 safety factor for pressure rating as stated in the most recent catalog.

JRCAT2401



® REGISTERED TRADEMARK OF STAR PIPE PRODUCTS

STAR® PIPE PRODUCTS
HOUSTON CORPORATE | TOLL FREE 1-800-999-3009 | FAX 281-558-9000
www.starpipeproducts.com

STAR® PIPE PRODUCTS



Super Flange® series 7200

Designed for use on Ductile Iron, Steel, PVC, PVCO and HDPE Pipes

Sizes 3" - 36"

TECHNICAL INFORMATION

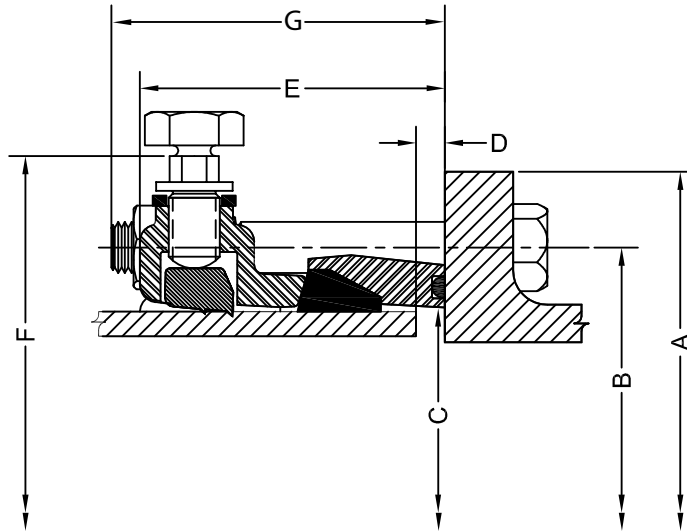

SUPER FLANGE® 7200 SPECIFICATIONS*											
NOM. SIZE	A	B	C	D MAX.	E	F	G	BOLTS		MAXIMUM JOINT DEFLECTION*	APPROX. WT. (LBS)
								SIZE	QTY.		
3	7.50	6.00	4.09	0.70	4.06	7.95	4.75	5/8 X 5 1/2	4	5.0°	13
4	9.00	7.50	4.93	0.60	4.18	9.22	4.56	5/8 X 5 1/2	8	5.0°	20
6	11.00	9.50	7.03	0.80	4.43	11.32	5.00	3/4 X 6	8	5.0°	29
8	13.50	11.75	9.18	0.90	4.60	13.29	4.88	3/4 X 6	8	5.0°	35
10	16.00	14.25	11.23	1.00	4.62	15.50	6.31	7/8 X 7 1/2	12	3.0°	60
12	19.00	17.00	13.33	1.00	4.75	17.50	6.25	7/8 X 7 1/2	12	3.0°	72
14	21.00	18.75	15.45	1.30	5.13	19.54	6.62	1 X 8	12	2.0°	89
16	23.50	21.25	17.55	1.30	5.18	21.64	6.56	1 X 8	16	2.0°	110
18	25.00	22.75	19.65	1.30	5.23	23.74	6.94	1 1/8 X 8 1/2	16	1.5°	140
20	27.50	25.00	21.75	1.30	5.24	25.84	6.81	1 1/8 X 8 1/2	20	1.5°	165
24	32.00	29.50	25.95	1.30	5.28	30.04	6.62	1 1/4 X 8 1/2	20	1.0°	198
30	38.75	36.00	32.18	2.00	6.00	36.58	7.88	1 1/4 X 10	28	1.0°	362
36	46.00	42.75	38.48	2.00	6.00	42.88	8.12	1 1/2 X 10 1/2	32	1.0°	541

* All dimensions in inches except where indicated.

STAR® PIPE PRODUCTS



Super Flange[®] series 7200
 Designed for use on Ductile Iron, Steel and PVC Pipes
 Sizes 3" - 36"

TECHNICAL INFORMATION

TABLE A. Maximum Working Pressure Rating with Occasional or Recurring Surges in PSI for Pipes Made to a CIOD Diameter Regimen

NOM. SIZE (IN)	ACTUAL PLASTIC PIPE OD	DUCTILE IRON	AWWA C900 PVC									AWWA C909 PVCO	AWWA C906 HDPE*						
			DR14	DR17	DR18	DR21	DR25	DR27.5	DR32.5	DR41	DR51		PC235	DR 7.3	DR 9	DR 9.3	DR11	DR13.5	DR17
3	3.96	350	-	-	-	-	-	-	-	-	-	-	-	-	-	-	-	-	-
4	4.80	350	305	250	235	200	165	-	-	-	-	235	254	200	193	160	130	100	100
6	6.90	350	305	250	235	200	165	-	-	-	-	235	254	200	193	160	130	100	100
8	9.05	350	305	250	235	200	165	-	-	-	-	235	254	200	193	160	130	100	100
10	11.10	350	305	250	235	200	165	-	-	-	-	**	254	200	193	160	130	100	100
12	13.20	350	305	250	235	200	165	-	-	-	-	200	254	200	193	160	130	100	100
14	15.30	350	305	250	235	200	165	150	125	-	-	165	-	200	193	160	130	100	100
16	17.40	350	305	250	235	200	165	150	125	-	-	165	-	-	-	160	-	-	-
18	19.50	300	-	-	235	200	165	150	125	-	-	150	-	-	-	160	-	-	-
20	21.60	250	-	-	235	200	165	150	125	-	-	-	-	-	-	-	-	-	-
24	25.80	200	-	-	-	-	165	150	125	-	-	-	-	-	-	-	-	-	-
30	32.00	150	-	-	-	-	-	-	-	-	-	-	-	-	-	-	-	-	-
36	38.30	150	-	-	-	-	-	-	-	-	-	-	-	-	-	-	-	-	-

* A stainless steel pipe stiffener (provided by others) is required for the Series 7200 to be installed on HDPE pressure pipe. The stiffener must be installed in the HDPE pipe before installing the Series 7200. The stainless steel pipe stiffener must be of sufficient length to support the full bearing length of the restrainer.

** The Series 7200 is not recommended for 10-inch AWWA C909 PVCO pressure pipe.

TABLE B. Maximum Working Pressure Rating with Occasional or Recurring Surges in PSI for Pipes Made to an IPS Diameter Regimen

NOM. SIZE (IN)	ACTUAL PLASTIC PIPE OD*	STEEL PIPE	ASTM D2241 PVC			AWWA C901 and AWWA C906 HDPE**					
			SDR17	SDR21	SDR26	DR 7.3	DR 9	DR 9.3	DR 11	DR 13.5	DR 17
3	3.50	350	250	200	160	254	200	-	160	130	100
4	4.50	350	250	200	160	254	200	193	160	130	100
6	6.63	350	250	200	160	254	200	193	160	130	100
8	8.63	350	250	200	160	254	200	193	160	130	100
10	10.75	350	250	200	160	254	200	193	160	130	100
12	12.75	350	250	200	160	254	200	193	160	130	100

* A transition gasket is required for use with pipes made to an IPS diameter regimen.

** A stainless steel pipe stiffener (provided by others) is required for the Series 7200 to be installed on HDPE pressure pipe. The stiffener must be installed in the HDPE pipe before installing the Series 7200. The stainless steel pipe stiffener must be of sufficient length to support the full bearing length of the restrainer.

STAR[®] PIPE PRODUCTS



Super Flange® series 7200

Designed for use on Ductile Iron, Steel and PVC Pipes

Sizes 3" - 36"

INSTALLATION INSTRUCTIONS - SIZES 3" - 36"

SIZE (IN)	INFORMATION
3	Designed for use on Ductile Iron, Steel Pipe, IPS OD PVC pressure pipe, and IPS OD HDPE pressure pipe. Spacers are not provided on this size.
4 - 12	Designed for use on Ductile Iron, Steel Pipe, PVC Pressure Pipe, PVCO Pressure Pipe, and HDPE Pressure Pipe. 1. For Ductile Iron, AWWA C900 PVC Pressure Pipe, AWWA C909 PVCO Pressure Pipe, and CIOD HDPE Pressure Pipe, DO NOT REMOVE spacers. 2. For Steel, IPS PVC Pressure Pipe, and IPS HDPE Pressure pipe, spacers MUST BE REMOVED.
14 - 24	Spacers are not provided in these sizes. 1. For Ductile Iron in all of these sizes. 2. For AWWA C900 PVC pressure pipe in all these sizes. 3. For AWWA C909 PVCO pressure pipe in 14" to 18". 4. For AWWA C906 HDPE pressure pipe with a CIOD in 14" to 18".
30 - 36	Spacers are not provided in these sizes. Designed for Ductile Iron pipe only in these sizes.

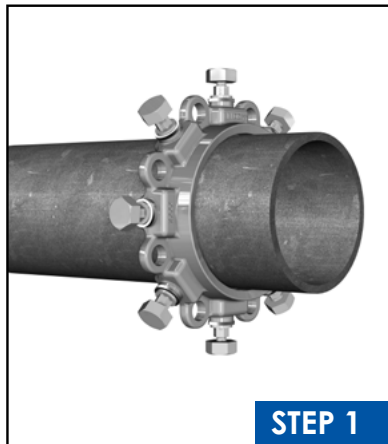
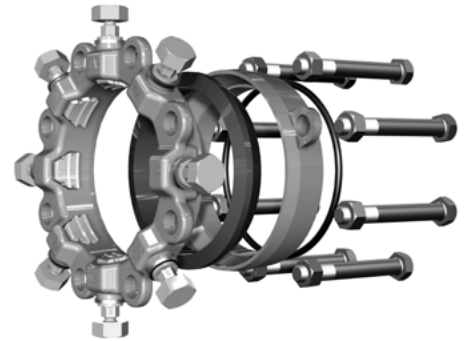

STEP 1

Pipe to be cut to required length and surface to be clean. Insert 7200 gland assembly with lip of the gland facing the plain end of pipe.

NOTE: If installing the Series 7200 on HDPE pressure pipe, a stainless steel pipe stiffener (provided by others) is required. The stiffener must be installed in the HDPE pipe before installing the Series 7200. The stainless steel pipe stiffener must be of sufficient length to support the full bearing length of the unit.

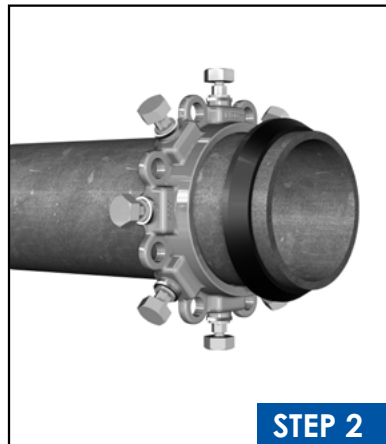

STEP 2

Brush both the gasket and the plain end of pipe with soapy water or approved pipe lubricant, which meets ANSI/AWWA C111/A21.11. Slide the MJ gasket over the pipe with beveled edge towards the pipe end.

IMPORTANT: When used on IPS pressure pipe, a transition MJ gasket must be used.



STEP 3

Insert 7200 ring onto the pipe with O-Ring facing the flange component. O-Ring has been glued in place at the factory.

(Continued on next page)

STAR® PIPE PRODUCTS



Super Flange[®] series 7200

Designed for use on Ductile Iron, Steel and PVC Pipes

Sizes 3" - 36"

INSTALLATION INSTRUCTIONS - SIZES 3" - 36" (Continued)

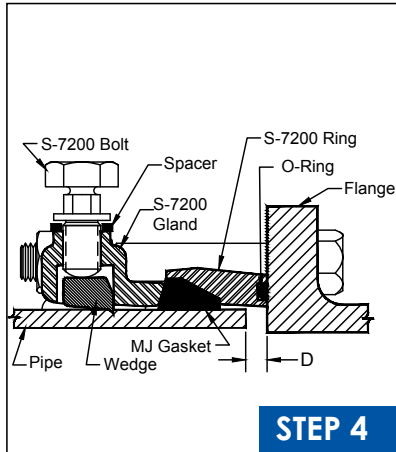

STEP 4

Move the pipe towards the flange face bringing it within max. allowable distance "D" from flange face. Refer to Table A for max. allowable distance "D" and Max. allowable deflection of pipe.



STEP 5

Assemble the joint using supplied flange bolts. Torque all flange bolts in alternating manner as per the torque values given in the table. Make joint deflection if required before actuating torque off bolts. Joint deflection must not exceed the given values and must not make the separation any more than max. allowable distance "D."



STEP 6

Tighten torque off bolts in an alternate manner such that all wedges touch the pipe. Never turn a single bolt over 180 degrees without alternating to another bolt.

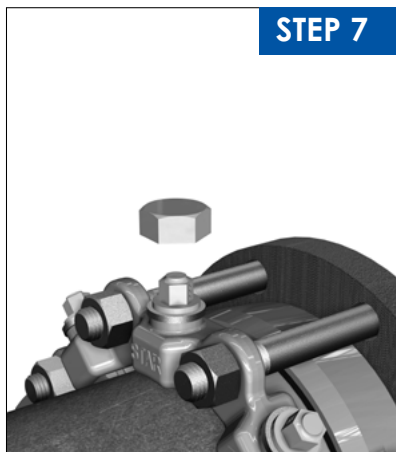

STEP 7

Continue tightening the bolts in an alternate manner until torque off bolt heads twist off. If removal is necessary, use 5/8 inch hex head provided. If reassembly is required, assemble the joint in the same manner following steps 1 to 6 and tighten wedge bolts to 90 ft-lbs.

TABLE A			
SIZE (IN)	MAX. ALLOWABLE DISTANCE "D" (IN)	MAX. ALLOWABLE DEFLECTION	FLANGE BOLT TORQUE (FT-LBS)
3	0.7	5°	45 - 60
4	0.6	5°	75 - 90
6	0.8	5°	75 - 90
8	0.9	5°	90 - 110
10 - 12	1.0	3°	90 - 110
14 - 16	1.3	2°	90 - 110
18 - 20	1.3	1.5°	90 - 110
24	1.3	1.0°	90 - 110
30 - 36	2.0	1.0°	110 - 130

STAR[®] PIPE PRODUCTS

